

Hemp blocks

Your materials for a sustainable construction.



2023

Catalogue



Introduction

Hemp blocks.....	3
------------------	---

Hemp blocks

7 cm hemp block.....	8
9 cm hemp block.....	9
12 cm hemp block.....	10
15 cm hemp block.....	11
20 cm hemp block.....	12
25 cm hemp block.....	13
30 cm hemp block.....	14
36 cm hemp block.....	15
30 cm and 36 cm drilled block – Hempro system.....	16
30 cm and 36 cm U-block – Hempro system.....	17

Lintels

Lintels.....	18
--------------	----

Complementary products

Adhesive mortar.....	20
HL Mix.....	21
HempBag.....	22
ProKalk.....	23

Tools

Tools and saws.....	24
---------------------	----

Fasteners

Hooks and connectors.....	25
---------------------------	----

Masonry supports

Brackets.....	26
Angle bars.....	27

Coatings and finishes

Clay base.....	28
Clay finish.....	29
PCS Interior plaster.....	30



Why choose IsoHemp blocks?



1. Thermal regulation

They regulate the temperature thanks to their ability to diffuse accumulated heat. True thermal buffer; the internal temperature is kept constant and the impact of heat variations between day and night is significantly reduced.



2. Water regulation

They regulate humidity thanks to their high permeability to water vapour. They also act as a water buffer, thus providing a constant and healthy indoor climate for the building occupants.



3. Sound proofing

They dampen and absorb noise. As true sound dampeners, they allow the absorption or abatement of the majority of acoustic waves, thus protecting against noise pollution.



4. Resistance and reaction to fire

They do not catch fire and do not emit toxic fumes. Thanks to their excellent reaction to fire, they offer up to more than 2 hours of fire resistance depending on the finish and thickness.



5. 100% natural

As a 100% natural solution, they also have a positive carbon footprint. A pallet of hemp blocks IsoHemp stores 100kg of CO₂.



A house with hemp blocks
saves

5 TONS OF CO₂

**= 1 ROUND-THE-WORLD
TRIP BY CAR**



The applications



■ Construction

Regardless of the construction system you choose, hemp blocks fit perfectly into your project!

- **NEW 2.0 Hempro System**

For a 100% hemp construction. This 2.0 version of our Hempro system has interlocking blocks with many advantages:

- Quick installation
- Less glue needed
- Lighter blocks
- More resilient blocks

- **Pole-beam system (wood, steel, concrete)**

Hemp blocks allow for the creation of insulating and breathable mono-walls that do not require the use of any other insulation materials.

- **Wood frame**

Hemp blocks form the building envelope and provide the thermal inertia necessary for comfort in summer and winter alike.



Introduction

Hemp blocks



■ Renovation

When conducting building renovations, particular attention must be given to achieving a good match between the existing walls and the new materials used.

IsoHemp blocks guarantee efficient energy renovation both in internal and external insulation.



■ Interior walls

Create walls or separate rooms with hemp blocks to ensure lightness, simplicity, and acoustic comfort.



■ Floors

Using hemp blocks to insulate your floors makes your projects easier both in terms of speed and simplicity of application.

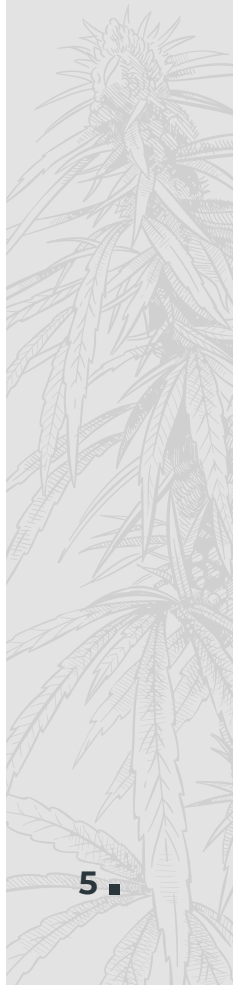

Technical characteristics

The IsoHemp blocks are very versatile and respond to many challenges, both for new buildings as renovations, whether in single-family or multi-family dwellings or commercial buildings. It is non-load-bearing and forms the insulating envelope of the building in combination with the supporting structure of the building.

1

Range of hemp blocks



A range of 8 thicknesses for all your construction and renovation projects.

2

Hempro range Interlocking blocks



A high-performance mono-wall system for 100% hemp buildings.





Summary table

Technical characteristics	Block 7	Block 9	Block 12	Block 15	Block 20	Block 25	Block 30	Block 36	Unit
	Hempro range/ Interlocking blocks								
Thickness	7,5	9	12	15	20	25	30	36	cm
Modular dimensions	60 x 30							60x20	cm
Number of blocks per m ²	5,5							8,3	blocks/m ²
Number of m ² per pallet	15,12	12,96	9,72	7,56	5,4	4,32	3,24	3	m ² /pallet
Maximum block weight	6,20	7,4	9,9	12,4	16,5	20,7	24,8	19,8	kg
Weight of the masonry	0,37	0,44	0,60	0,74	0,98	1,23	1,39	1,71	kN/m ²
Adhesive consumption	2,8	3,4	4,5	5,6	7,5	9,4	2,8	6,8	kg/m ²
Dry thermal resistance	1,12	1,34	1,79	2,24	3	3,73	4,48	5,37	m ² K/W
Thermal resistance at 50% RH	1,06	1,27	1,69	2,11	2,82	3,52	4,23	5,07	m ² K/W
Thermal conductivity λ	0,071								W/mK
Phase shift	4,9	5,9	7,9	9,8	13,1***	16,4***	19,7***	23,6***	h
Sound reduction index* R _w	37 (0;-2)	37 (-1;-3)	38 (-1;-3)	38 (0;-3)	40 (-1;-5)	41 (-1;-5)	42 (-1;-5)	44 (-1;-6)	dB
Acoustic absorption coefficient α	0,85								
Equivalent air layer thickness S _d	0,21	0,25	0,34	0,42	0,56	0,7	0,84	1	m
Water vapour resistance factor μ	2,8								
Compressive strength	0,22								MPa
Compressive strenght at ULS f _d	0,099								MPa
Reaction to fire	B, S1, d0								
Resistance to fire**	Non testé		45		120		240		min

Technical characteristics	P Blocks		U Blocks		Unit
	Hempro range / Interlocking blocks				
Thickness	30	36	30	36	cm
Modular dimensions	60 x 30	60x20	60x30		
Maximum block weight	21,7	16,9	15,5	19,3	kg
Recess section	15 x 15	18 x 18	15 x 42	18 x 42	cm
Cross-section of the recess	225	324	630	756	cm ²
Adhesive consumption	2,8	6,8	2,8	6,8	kg/m ²

* Coated hemp block 15mm on one side – simulated value

** Hemp block masonry plastered on the fire side

*** Insignificant considering a damping of more than 300

The hemp block

7 Block – Thickness 7,5 cm



PAL07EX

7 Block – Thickness 7,5 cm

The 7cm block is the thinnest block in the IsoHemp range. It's ideal for insulating from the inside in small spaces. Its thickness allows for quick and easy installation, without loss of living space. It's therefore particularly suitable for insulating small rooms or technical returns. This efficient block provides good thermal inertia and natural regulation of humidity inside rooms. It's a solution suitable for brick or stone walls, damp walls as well as bay returns.

Technical characteristics

	Value	Unit	Standard
Thickness	7,5	cm	
Modular dimensions	60 x 30	cm	
Number of blocks per m ²	5,5	blocks/m ²	
Maximum block weight	6,20	kg	
Weight of the masonry	0,37	kN/m ²	
Adhesive consumption	3	kg/m ²	
Dry thermal resistance	1,12	m ² K/W	EN 12667
Thermal resistance at 50% RH	1,06	m ² K/W	EN 12667
Phase shift λ	0,071	W/mK	EN 12667
Phase shift	4,9	h	ISO 13786
Sound reduction index* Rw	37 (0 ; -2)	dB	ISO 10140-2
Acoustic absorption coefficient α	0,85		EN ISO 354 : 2003
Equivalent air layer thickness Sd	0,21	m	EN ISO 12572
Water vapour resistance factor μ	2,8		EN ISO 12572
Compressive strength	0,22	MPa	EN 772-1
Compressive strenght at ULS fd	0,099	MPa	
Reaction to fire	B, s1, d0		NF EN 13501-1

* Coated hempblok 15mm on one side – Simulated value

Advantages

- Little loss of living space
- Natural humidity regulation
- The benefits of thermal inertia
- Quick and easy implementation

Packaging

	Value	Unit
Dimensions of a pallet	120 x 100 x 120	cm
Maximum weight of a pallet	546	kg
Number of blocks per pallet	84	blocks/pallet
Number of m ² per pallet	15,12	m ² /pallet
Number of blocks per m ²	5,5	blocks/m ²

Storage

Pallet with shelf stored outside	6 months
Open pallet and exterior wall in progress	3 months
Masonry under completed roof	1 year with a maximum of 1 winter

Applications



Interior insulation



9 Block – Thickness 9 cm

Technical characteristics

	Value	Unit	Standard
Thickness	9	cm	
Modular dimensions	60 x 30	cm	
Number of blocks per m ²	5,5	blocks/m ²	
Maximum block weight	7,4	kg	
Weight of the masonry	0,44	kN/m ²	
Adhesive consumption	3,6	kg/m ²	
Dry thermal resistance	1,34	m ² K/W	EN 12667
Thermal resistance at 50% RH	1,27	m ² K/W	EN 12667
Phase shift λ	0,071	W/mK	EN 12667
Phase shift	5,9	h	ISO 13786
Sound reduction index* Rw	37 (-1;-3)	dB	ISO 10140-2
Acoustic absorption coefficient α	0,85		EN ISO 354 : 2003
Equivalent air layer thickness Sd	0,25	m	EN ISO 12572
Water vapour resistance factor μ	2,8		EN ISO 12572
Compressive strength	0,22	MPa	EN 772-1
Compressive strenght at ULS fd	0,099	MPa	
Reaction to fire	B, s1, d0		NF EN 13501-1

The 9 cm block allows insulation from the inside with even higher thermal performance than block 7. Its thickness allows easy grooving to accommodate technical ducts. This block offers high moisture regulation, which allows it to be used to insulate old, damp walls or bay returns. From this thickness, hemp blocks also offer good sound absorption to improve the overall comfort of living rooms.

* Coated hempblok 15mm on one side – Simulated value

Advantages

- Thermal and acoustic insulation
- Natural humidity regulation
- Thermal inertia input
- Easy to attach objects

Packaging

	Value	Unit
Dimensions of a pallet	120 x 100 x 122	cm
Maximum weight of a pallet	560	kg
Number of blocks per pallet	72	blocks/pallet
Number of m ² per pallet	12,96	m ² /pallet
Number of blocks per m ²	5,5	blocks/m ²

Storage

Pallet with shelf stored outside	6 months
Open pallet and exterior wall in progress	3 months
Masonry under completed roof	1 year with a maximum of 1 winter

Applications



Interior insulation



Interior walls

The hemp block
9 Block – Thickness 9 cm



The hemp block

12 Block – Thickness 12 cm



12 Block – Thickness 12

The 12 cm block fulfils all interior insulation needs for renovations of old buildings. It regulates humidity naturally, which allows it to be used to insulate interior and exterior walls that are more humid. This block offers good thermal phase-shift, regulates heat, and improves living comfort significantly. Its thickness also allows it to be used in interior masonry. This block also offers very good sound insulation. From this thickness, hemp blocks are an efficient solution for exterior insulation of buildings.

Technical characteristics

	Value	Unit	Standard
Thickness	12	cm	
Modular dimensions	60 x 30	cm	
Number of blocks per m ²	5,5	blocks/m ²	
Maximum block weight	9,9	kg	
Weight of the masonry	0,60	kN/m ²	
Adhesive consumption	4,7	kg/m ²	
Dry thermal resistance	1,79	m ² K/W	EN 12667
Thermal resistance at 50% RH	1,69	m ² K/W	EN 12667
Phase shift λ	0,071	W/mK	EN 12667
Phase shift	7,9	h	ISO 13786
Sound reduction index* Rw	38 (-1;-3)	dB	ISO 10140-2
Acoustic absorption coefficient α	0,85		EN ISO 354 : 2003
Equivalent air layer thickness Sd	0,34	m	EN ISO 12572
Water vapour resistance factor μ	2,8		EN ISO 12572
Compressive strength	0,22	MPa	EN 772-1
Reaction to fire	B, s1, d0		NF EN 13501-1
Compressive strenght at ULS fd	0,099	MPa	
Resistance to fire with render	EI 45	min	EN 1364-1

* Coated hempblok 15mm on one side – Simulated value

** Hemp block masonry plastered on the fire side

Advantages

- Natural humidity control
- Thermal inertia input
- Quick and easy implementation
- Significant thermal phase-shift

Packaging

	Value	Unit
Dimensions of a pallet	120 x 100 x 122	cm
Maximum weight of a pallet	560	kg
Number of blocks per pallet	54	blocks/pallet
Number of m ² per pallet	9,72	m ² /pallet
Number of blocks per m ²	5,5	blocks/m ²

Storage

Pallet with shelf stored outside	6 months
Open pallet and exterior wall in progress	3 months
Masonry under completed roof	1 year with a maximum of 1 winter

Applications

-  Interior insulation
-  Exterior insulation
-  Interior walls



15 Block – Thickness 15 cm

Technical characteristics

The 15cm block, like the 20cm block, is a very versatile block. It can be used to build as well as to insulate, both inside and out. It offers excellent thermal insulation for optimal comfort in summer and winter alike. It also provides very good acoustic comfort and humidity regulation of walls. This block can be used as formwork for hemp concrete and as a masonry block in post-beam systems, as well as for partitions. It also offers very strong exterior insulation and provides excellent support for all types of rendering and cladding.

	Value	Unit	Standard
Thickness	15	cm	
Modular dimensions	60 x 30	cm	
Number of blocks per m ²	5,5	blokken/m ²	
Maximum block weight	12,4	kg	
Weight of the masonry	0,74	kN/m ²	
Adhesive consumption	5,8	kg/m ²	
Dry thermal resistance	2,24	m ² K/W	EN 12667
Thermal resistance at 50% RH	2,11	m ² K/W	EN 12667
Phase shift λ	0,071	W/mK	EN 12667
Phase shift	9,8	h	ISO 13786
Sound reduction index* Rw	38 (0 ; -3)	dB	ISO 10140-2
Acoustic absorption coefficient α	0,85		EN ISO 354 : 2003
Equivalent air layer thickness Sd	0,42	m	EN ISO 12572
Water vapour resistance factor μ	2,8		EN ISO 12572
Compressive strength	0,22	MPa	EN 772-1
Compressive strenght at ULS fd	0,099	MPa	
Reaction to fire	B, s1, d0		NF EN 13501-1
Resistance to fire with render	EI 45	min**	EN 1364-1

* Coated hempblok 15mm on one side – Simulated value

** Value validated and tested with a 12cm thick block - Hemp block masonry plastered on the fire side

Advantages

- Highly resistant exterior insulation
- Significant thermal phase-shift
- Summer and winter comfort
- Excellent support for renders and cladding

Packaging

	Value	Unit
Dimensions of a pallet	120 x 100 x 119	cm
Maximum weight of a pallet	546	kg
Number of blocks per pallet	42	blokken/pallet
Number of m ² per pallet	7,56	m ² /pallet
Number of blocks per m ²	5,5	blokken/m ²

Storage

Pallet with shelf stored outside	6 months
Open pallet and exterior wall in progress	3 months
Masonry under completed roof	1 year with a maximum of 1 winter

Applications

- Interior insulation
- Exterior insulation
- Interior walls
- New buildings





20 Block – Thickness 20

The 20 cm block is very versatile and is specifically suited to new constructions and extensions. This masonry block is compatible with all construction systems (wood frame, post-beam system, classic construction, etc.). This breathable and insulating block guarantees excellent thermal phase shift in summer and winter alike. When used for interior partitions, it offers very high acoustic comfort. It can also be used in interior and exterior insulation of existing buildings that require very high thermal performance.

Technical characteristics

	Value	Unit	Standard
Thickness	20	cm	
Modular dimensions	60 x 30	cm	
Number of blocks per m ²	5,5	blocks/m ²	
Maximum block weight	16,5	kg	
Weight of the masonry	0,98	kN/m ²	
Adhesive consumption	7,8	kg/m ²	
Dry thermal resistance	3	m ² K/W	EN 12667
Thermal resistance at 50% RH	2,82	m ² K/W	EN 12667
Phase shift λ	0,071	W/mK	EN 12667
Phase shift	13,1	h	ISO 13786
Sound reduction index* Rw	40 (-1;-5)	dB	ISO 10140-2
Acoustic absorption coefficient α	0,85		EN ISO 354 : 2003
Equivalent air layer thickness Sd	0,56	m	EN ISO 12572
Water vapour resistance factor μ	2,8		EN ISO 12572
Compressive strength	0,22	MPa	EN 772-1
Compressive strenght at ULS fd	0,099	MPa	
Reaction to fire	B, s1, d0		NF EN 13501-1
Resistance to fire with render	EI 120	min	EN 1364-1

* Coated hempblok 15mm on one side – Simulated value

** Hemp block masonry plastered on the fire side

*** Insignificant considering a damping of more than 300

Advantages

- Summer and winter comfort
- Significant thermal phase-shift
- Quick and easy implementation
- Significant durability of the insulation and its performance

Packaging

	Value	Unit
Dimensions of a pallet	120 x 100 x 114	cm
Maximum weight of a pallet	521	kg
Number of blocks per pallet	30	blocks/pallet
Number of m ² per pallet	5,4	m ² /pallet
Number of blocks per m ²	5,5	blocks/m ²

Storage

Pallet with shelf stored outside	6 months
Open pallet and exterior wall in progress	3 months
Masonry under completed roof	1 year with a maximum of 1 winter

Applications





25 Block – Thickness 25

The hemp block

25 Block – Thickness 25 cm

Technical characteristics

The 25 cm block has the ideal thickness for interior or exterior insulation. It's very efficient and suitable for construction of new walls. It can be used in all existing building systems as an insulating masonry block. Its thermal resistance above 3.5 m²K/W guarantees high energy efficiency for optimal comfort in summer and winter alike. It provides humidity regulation and acoustic insulation for your building.

	Value	Unit	Standard
Thickness	25	cm	
Modular dimensions	60 x 30	cm	
Number of blocks per m ²	5,5	blocks/m ²	
Maximum block weight	20,6	kg	
Weight of the masonry	1,23	kN/m ²	
Adhesive consumption	9,7	kg/m ²	
Dry thermal resistance	3,5	m ² K/W	EN 12667
Thermal resistance at 50% RH	3,7	m ² K/W	EN 12667
Phase shift λ	0,071	W/mK	EN 12667
Phase shift	16,4	h	ISO 13786
Sound reduction index* Rw	41 (-1 ; -5)	dB	ISO 10140-2
Acoustic absorption coefficient α	0,85		EN ISO 354 : 2003
Equivalent air layer thickness Sd	0,7	m	EN ISO 12572
Water vapour resistance factor μ	2,8		EN ISO 12572
Compressive strength	0,22	MPa	EN 772-1
Compressive strenght at ULS fd	0,099	MPa	
Reaction to fire	B, s1, d0		NF EN 13501-1
Resistance to fire with render	EI 120	min**	EN 1364-1

* Coated hempblok 15mm on one side – Simulated value

** Value validated and tested with a 12cm thick block - Hemp block masonry plastered on the fire side

*** Insignificant considering a damping of more than 300

Advantages

- Significant thermal phase-shift
- Summer and winter comfort
- Quick and easy implementation
- Significant durability of the insulations and its performance

Packaging

	Value	Unit
Dimensions of a pallet	120 x 100 x 114	cm
Maximum weight of a pallet	521	kg
Number of blocks per pallet	24	blocks/pallet
Number of m ² per pallet	4,32	m ² /pallet
Number of blocks per m ²	5,5	blocks/m ²

Storage

Pallet with shelf stored outside	6 months
Open pallet and exterior wall in progress	3 months
Masonry under completed roof	1 year with a maximum of 1 winter

Applications

- Interior insulation
- Exterior insulation
- New buildings
- Floor & roof

The hemp block

30 Block – Thickness 30 cm



PAL30EX

30 Block – Thickness 30 cm

NEW 2.0 Hempro System

Technical characteristics

The 30 cm block is particularly suited to new low-energy constructions. This insulating masonry block can be combined with all construction systems and offers optimal compatibility with the Hempro system. The thermal phase shift of this very efficient block exceeds 19h and ensures optimal temperature in summer and winter while regulating the humidity of your home. The block also dampens sound waves and eliminates noise pollution. Like block 36, it can be used in existing constructions as state-of-the-art interior or exterior insulation.

	Value	Unit	Standard
Thickness	30	cm	
Modular dimensions	60 x 30	cm	
Number of blocks per m ²	5,5	blokken/m ²	
Maximum block weight	24,8	kg	
Weight of the masonry	1,39	kN/m ²	
Adhesive consumption	5,8	kg/m ²	
Dry thermal resistance	4,48	m ² K/W	EN 12667
Thermal resistance at 50% RH	4,23	m ² K/W	EN 12667
Phase shift λ	0,071	W/mK	EN 12667
Phase shift***	19,7	h	ISO 13786
Sound reduction index* Rw	42 (-1;-5)	dB	ISO 10140-2
Acoustic absorption coefficient α	0,85		EN ISO 354 : 2003
Equivalent air layer thickness Sd	0,84	m	EN ISO 12572
Water vapour resistance factor μ	2,8		EN ISO 12572
Compressive strength	0,22	MPa	EN 772-1
Compressive strenght at ULS fd	0,099	MPa	
Reaction to fire	B, s1, d0		NF EN 13501-1
Resistance to fire with render	EI 120	min**	EN 1364-1

* Coated hempblok 15mm on one side – Simulated value

** Value validated and tested with a 30cm thick block- Hemp block masonry plastered on the fire side

*** Insignificant considering a damping of more than 300

Advantages

- Durability of the insulator and its performances
- Phase shift (>19h)
- Summer and winter comfort
- Open to water vapour diffusion

Packaging

	Value	Unit
Dimensions of a pallet	120 x 100 x 104	cm
Maximum weight of a pallet	471	kg
Number of blocks per pallet	18	blokken/pallet
Number of m ² per pallet	3,24	m ² /pallet
Number of blocks per m ²	5,5	blokken/m ²

Storage

Pallet with shelf stored outside	6 months
Open pallet and exterior wall in progress	3 months
Masonry under completed roof	1 year with a maximum of 1 winter

Applications



Interior insulation



External insulation



New buildings



Floor & roof

Please refer to the Hempro conception guide before ordering. If in doubt, contact IsoHemp's technical department.



36 Block – Thickness 36 cm

NEW 2.0 Hempro System

Technical characteristics

The 36 cm block is the reference block for new construction with very high thermal performance (very low energy). When associated with a load-bearing structure (Hempro system, post-beam system, etc.), it creates the entire envelope of a building. With high-level insulation (thermal phase shift > 23h), the block provides optimal comfort both through its thermal and acoustic qualities and its humidity regulation properties.

	Value	Unit	Standard
Thickness	36	cm	
Modular dimensions	60 x 20	cm	
Number of blocks per m ²	8,3	blocks/m ²	
Maximum block weight	19,8	kg	
Weight of the masonry	1,71	kN/m ²	
Adhesive consumption	7,5	kg/m ²	
Dry thermal resistance	5,37	m ² K/W	EN 12667
Thermal resistance at 50% RH	5,07	m ² K/W	EN 12667
Phase shift λ	0,071	W/mK	EN 12667
Phase shift***	23,6	h	ISO 13786
Sound reduction index* Rw	44 (-1;-6)	dB	ISO 10140-2
Acoustic absorption coefficient α	0,85		EN ISO 354 : 2003
Equivalent air layer thickness Sd	1	m	EN ISO 12572
Water vapour resistance factor μ	2,8		EN ISO 12572
Compressive strength	0,22	MPa	EN 772-1
Compressive strenght at ULS fd	0,099	MPa	
Reaction to fire	B, s1, d0		NF EN 13501-1
Resistance to fire with render	EI 120	min**	EN 1364-1

* Coated hempblok 15mm on one side – Simulated value

** Value validated and tested with a 30cm thick block- Hemp block masonry plastered on the fire side

*** Insignificant considering a damping of more than 300

Advantages

- Very significant phase shift (>23h)
- Summer and winter comfort
- Open to water vapour diffusion
- Excellent support for renders and claddings

Packaging

	Value	Unit
Dimensions of a pallet	120 x 100 x 114	cm
Maximum weight of a pallet	521	kg
Number of blocks per pallet	25	blocks/pallet
Number of m ² per pallet	3	m ² /pallet
Number of blocks per m ²	8,3	blocks/m ²

Storage

Pallet with shelf stored outside	6 months
Open pallet and exterior wall in progress	3 months
Masonry under completed roof	1 year with a maximum of 1 winter

Applications

- Interior insulation
- External insulation
- New buildings
- Floor & roof

The hemp block
36 Block – Thickness 36 cm





PAL30PEX | PAL36PEX

Drilled block

NEW 2.0 Hempro System

Technical characteristics

Vertical chaining block of 30cm or 36cm

Used for new constructions, 30 cm or 36 cm perforated blocks allow the creation of load-bearing structures (Hempro system) to create the complete envelope of your home from hemp blocks. This block has a vertical rectangular recess intended to create a reinforced concrete supporting column. The drilled block serves as formwork and insulation for the concrete column. Using this system creates optimal homogeneity while preventing thermal bridges and regulating humidity. It's associated with U-blocks to create collar beams.

	P Blocks		Unit
Thickness	30	36	cm
Modular dimensions	60 x 30	60 x 20	cm
Maximum block weight	21,7	16,9	kg
Recess section	15 x 15	18 x 18	cm
Cross-section of the recess	225	324	cm ²
Adhesive consumption	3,8	6,8	kg/m ²

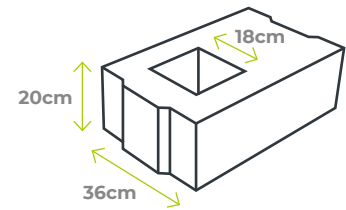
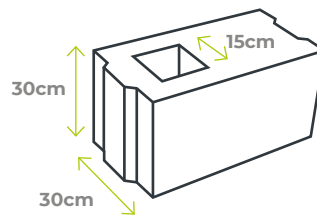

Advantages

- Homogeneity of the wall
- Economical solution
- Summer and winter comfort
- Open to water vapour diffusion

Packaging

	Value		Unit
	PAL30PEX	PAL36PEX	
Dimensions of a pallet	120 x 100 x 104	120 x 100 x 114	cm
Maximum weight of a pallet	415	446	kg
Number of blocks per pallet	18	25	blocks/pallet
Number of m ² per pallet	3,24	3	m ² /pallet
Number of blocks per m ²	5,5	8,3	blocks/m ²
Storage	3		months/exterior
Storage life	2		years if covered

Applications



New buildings



PAL30UEX | PAL36UEX

U-block

NEW 2.0 Hempro System

Technical characteristics

Horizontal chaining block of 30cm or 36cm

The 30 cm or 36 cm U-block is a hemp block intended for new constructions, allowing the creation of a complete load-bearing structure. This block has a horizontal recess intended to create a reinforced concrete supporting column for the building. It serves as formwork and allows the beams to be cast on which the floor and roof are placed. When associated with drilled blocks, it makes it possible to create a complete hemp block envelope, preventing thermal bridges and allowing your building to achieve homogeneous thermal performance over the whole of its envelope while ensuring good moisture regulation over its entire surface.

	U-block		Unit
Thickness	30	36	cm
Modular dimensions	60 x 30		cm
Maximum block weight	15,5	19,3	kg
Recess section	15 x 42	18 x 42	cm
Cross-section of the recess	630	756	cm ²
Adhesive consumption	5,8	7,5	kg/m ²

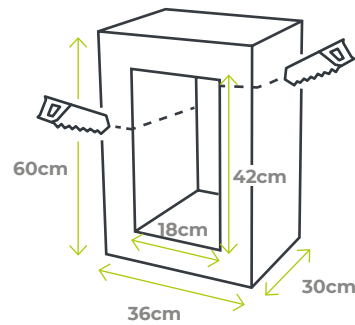
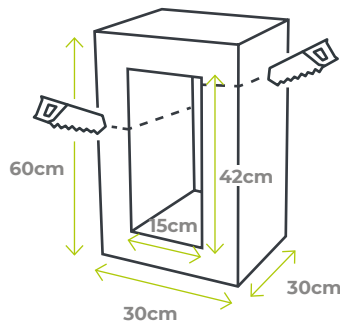

Advantages

- Homogeneity of the wall
- Economical solution
- Summer and winter comfort
- Open to water vapour diffusion

Packaging

	Value		Unit
	PAL30UEX	PAL36UEX	
Dimensions of a pallet	120 x 100 x 104	120 x 100 x 114	cm
Maximum weight of a pallet	304	315	kg
Number of blocks per pallet	18	15	blocks/pallet
Number of m ² per pallet	3,24	2,7	m ² /pallet
Number of blocks per m ²	5,5		blocks/m ²
Storage	3		months/exterior
Storage life	2		years if covered

Applications



New buildings

The hemp block
U-block

Lintels

For all openings



Lintels

IsoHemp lintels are prefabricated hemp concrete lintels strengthened by a reinforced concrete centre used for door and window openings in hemp block masonry construction. They are ideally suited for new build and interior and exterior renovations. They enable the elimination of thermal bridges and the achievement of an encompassing and continuous insulating envelope IsoHemp lintels are available in 9cm, 12cm, 15cm, 20cm and 30cm and in various lengths.

How to choose your lintel?

The lintel supports the masonry above the opening that's been created. According to the vault principle, the IsoHemp lintel only takes on the triangular load of the masonry ($P\Delta$).



Advantages

- Suppression of thermal bridges
- Identical and continuous support for the final render
- Saves time on-site
- Quick and easy implementation



Packaging

Availabilities

Sale	By part or by order
Availability period	15 working days
Storage	3 months/exterior
Storage life	2 years/covered



References	Window opening max. (cm)	Dimensions (cm)			Weight max. (kg)	Handling hooks*
		L (Length)	t (Thickness)	h (Height)		
9 cm thickness						
LIN09-120-20	80	120	9	20	31	no
LIN09-160-20	120	160	9	20	42	no
LIN09-200-20	160	200	9	20	52	no
LIN09-240-20	180	240	9	20	63	no
12 cm thickness						
LIN12-120-20	80	120	12	20	35	no
LIN12-160-20	120	160	12	20	46	no
LIN12-200-20	160	200	12	20	58	no
LIN12-240-20	180	240	12	20	69	no
15 cm thickness						
LIN15-120-20	80	120	15	20	51	no
LIN15-160-20	120	160	15	20	68	no
LIN15-200-20	160	200	15	20	85	yes
LIN15-240-20	180	240	15	20	102	yes
LIN15-300-20	240	300	15	20	127	yes
20 cm thickness						
LIN20-120-20	80	120	20	20	69	yes
LIN20-160-20	120	160	20	20	92	yes
LIN20-200-20	160	200	20	20	115	yes
LIN20-240-20	180	240	20	20	139	yes
LIN20-300-20	240	300	20	20	173	yes
25 cm thickness						
LIN25-120-20	80	120	25	20	75	yes
LIN25-160-20	120	160	25	20	100	yes
LIN25-200-20	160	200	25	20	125	yes
LIN25-240-20	180	240	25	20	150	yes
LIN25-300-20	240	300	25	20	187	yes
30 cm thickness						
LIN30-120-20	80	120	30	20	80	yes
LIN30-160-20	120	160	30	20	107	yes
LIN30-200-20	160	200	30	20	134	yes
LIN30-240-20	180	240	30	20	160	yes
LIN30-300-20	240	300	30	20	201	yes

* From 70kg the lintels are equipped with hooks for easy handling.

IsoHemp SA declines all responsibility for misinterpretation of this table. If in doubt, please contact the IsoHemp technical department.

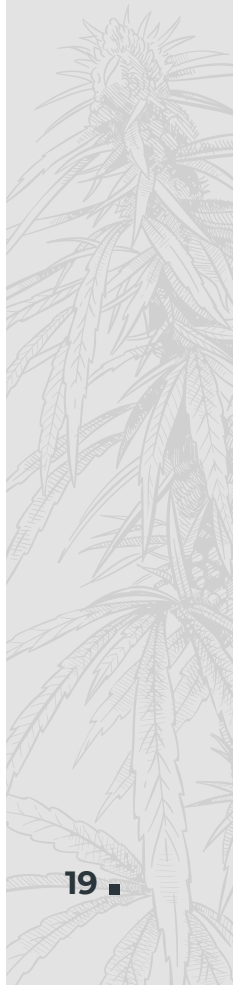



Adhesive mortar

Technical characteristics

Natural adhesive for hemp blocks

IsoHemp adhesive mortar has been specially developed for the implementation of hemp blocks for interior and exterior use. It is a lime-based mortar that is used in place of traditional mortar.

	Value	Unit
Bulk density	1400	kg/m ³
Mixing	7-8	l/bag
Usage time	1	hour
Lifespan	5 à 30	degrees
Drying time	36	hours

Tips :

25kg of adhesive mortar represents 20l of unmixed product.

Consumption

Consumption* for thin joints of 3mm**

Thickness	Quantity	Unit
7 cm block	2,8	kg/m ²
9 cm block	3,4	kg/m ²
12 cm block	4,5	kg/m ²
15 cm block	5,6	kg/m ²
20 cm block	7,5	kg/m ²
25cm block	9,4	kg/m ²
30 cm block	2,8	kg/m ²
36 cm block	6,8	kg/m ²
30 cm O block	2,8	kg/m ²
36 cm O block	6,8	kg/m ²
30 cm U block	2,8	kg/m ²
36 cm U block	6,8	kg/m ²

** It is laid in a thin joint of approx. 3 mm using the dedicated trowel (see tools).

Advantages

- Quick and easy installation
- A 100% natural product
- Manual or machine mixing
- Fast implementation

Packaging

	Value	Unit
Dimensions of a pallet	120 x 100 x 85	cm
Maximum weight of a pallet	1000	kg
Number of bags per pallet	40	bags/pallet
Bag weight	25	kg
Storage	Dry and away from moisture	
Storage life	6 months from production date	



HLM B

HL Mix

Technical characteristics

	Value	Unit
Bulk density	270	kg/m ³
Wet thermal conductivity at 50% RH	0,068	W/mK

IsoHemp HL Mix is an aggregate of hemp concrete made from crushed hemp blocks. It is a dried product and can be applied quickly. Used as filling between the joints of a floor or a roof, it greatly improves the summer comfort of the building. It can also be used as filling between existing walls and IsoHemp block masonry.

HL Mix
Complementary products

Advantages

- Ease of implementation
- Dry product
- Circular economy
- 100% natural product

Packaging

	Value	Unit
Dimensions of a pallet	120 x 100 x 115	cm
Maximum weight of a pallet	350	kg
Bag weight	335	kg
Storage	Dry and away from moisture	
Storage life	6	months



Hempbag

Technical characteristics

Hemp for construction

The bag of IsoHemp hemp is the guarantee of using quality aggregate especially suitable for building applications. Mixed with ProKalk lime, this hemp enables the manufacture of lightweight insulating concrete quickly and easily prepared on site. It can be used both for renovation and in new builds.

	Value	Unit
Bulk density	~ 100	kg/m ³
Particle size	2 à 25	mm

Advantages

- Suitable for building
- Performance guarantee with ProKalk
- Very low dust levels
- Locally sourced

Packaging

	Value	Unit
Dimensions of a pallet	120 x 80 x 240	cm
Weight of a pallet	420	kg
Number of bags per pallet	21	bags/pallet
Volume of a bag	200	L
Storage	Dry and in the shade	
Storage life	6	months



PROK

ProKalk

Technical characteristics

Pre-formulated binder for hempcrete

ProKalk lime is a pre-formulated binder specially adapted for the manufacturing of hempcrete. It is composed of hydraulic lime and aerated lime. It is a ready to use product for preparing mixtures directly on-site, to prevent any risk of incorrect dosage. It is used both for manual application in a mixer, as well as in a dedicated hemp concrete spraying machine.

	Value	Unit
Bulk density	700	kg/m ³
Usage time	30	min

Applications

	Dry density	Dosage		
		ProKalk (kg)	Chanvre (L)	Eau (L)
Wall	300 kg/m ³	40	200	50
Filling	200 kg/m ³	20	200	25

💡 Tips :

25kg of adhesive mortar represents 20l of unmixed product.

Advantages

- A 100% natural product
- Suitable for mixing and spraying machines
- Insulation from cold and heat
- Humidity control

Packaging

	Value	Unit
Dimensions of a pallet	120 x 100 x 95	cm
Weight of a pallet	1000	kg
Number of bags per pallet	48	bags/pallet
Volume of a bag	20	kg
Storage	Dry and away from moisture	
Storage life	9 months from production date	

Complementary products
 ProKalk



Tools and saws

Tools and saws available for sale, recommended for on-site use with hemp blocks.

Trowel



Teeth : 7mm x 7mm

Ref.

TRU07 For 7cm and 30cm blocks

TRU09 For 9cm and 36cm blocks

TRU12 For 12cm blocks

TRU15 For 15cm blocks

TRU20 For 20cm blocks

TRU25 For 25cm blocks

Blocks scraper



Ref. : GRAT

Tun



Ref. : CUV

Mallet



Weight : 0,720kg

Ref. : MAIL

Widia blade hand saw



Ref. : SCIE MAN

Alligator saw



Cutting length : 45 cm
Power : 1700 W

We recommend this electric Alligator saw for cutting IsoHemp hempcrete blocks on all types of construction sites.

Ref. : SCIE ALL

Band saw



Cutting height : 50 cm
Single phase 220volts

We recommend this band saw for cutting IsoHemp blocks for larger projects.

Ref. : SCIE RUB



Hammer-in hooks

The use of hammer-in hooks is essential for fixing hemp blocks to a supporting concrete, terracotta, or brick masonry structure. The hook is fixed in the existing wall and is then sealed in the IsoHemp hemp block masonry joint. The hooks are manufactured from galvanised wire with a 3,5mm thickness.

Reference*	Usage	Length total	Depth of anchor	Working length
CROF	All types of blocks	18 cm	4 cm	14 cm
Packaging		500 pieces		
Number of fasteners per m²**				
For renovation from the inside			3 hooks per m ²	
For renovation from the outside			5 hooks per m ²	



* Plug not supplied
 ** Calculated with a wind load of 65 daN/m² at ULS. For other configurations, please contact our technical department.

Connector brackets

The use of brackets is recommended to create a mechanical link between the hemp blocks and the existing structure. They are recommended for securing to the frame (timber frame and beam-column) and on their own for interior and exterior use.

Ref.	Usage	L Length	h Height	w Width	Thickness
EQLI08	Connection 7, 9 and 12 cm blocks	80 mm	5 cm	2 cm	
EQLI14	Connection 15, 20, 25, 30 and 36 blocks	140 mm	5 cm	2 cm	
EQLI-IPE	Metal structure connection	155		4	2,5 mm
EQLI-PLA	Ceiling connection	103	90	22	0,7 mm
EQLI-DIL	Movement joint connection	175		22	0,7 mm
Packaging		100 pieces			



EQLI08



EQLI14



EQLI-IPE



EQLI-PLA



EQLI-DIL

Please refer to the Hempro conception guide before ordering. If in doubt, contact IsoHemp's technical department.

Screws for blocks

These screws are suitable for fastening objects with a maximum weight of 37kg per anchor point. They can be fixed directly in the hempcrete blocks without pegs. If a plaster or a finishing plate has been added to the hempcrete blocks, you can still insert these screws directly into the wall. These screws are made of galvanised steel.

References	Usage	Packaging
VIS06-100	6x100mm screw	150 pieces
VIS08-160	8x160mm screw	50 pieces



Table of allowable loads

Anchoring depth according to test		At the axis	Crosswise
Ø 6	7 cm	18 daN	26 daN
Ø 8	9,5 cm	34 daN	37 daN



Brackets

Technical characteristics

Window passage

The use of brackets is advised to maintain hemp blocks above doors and windows when an IsoHemp lintel is not being used. This solution should be favoured in interior renovation mainly when the height to be insulated above the bay is low and there are only a few rows of blocks to be laid. The bracket can also be used as a link between two long thin lintels as well as to distribute and support the load in some applications.

Ref.	Usage	Weight approx	L	I	h
EQ07	7cm block	0,4 kg	15 cm	5 cm	5 cm
EQ09	9cm block	0,5 kg	15 cm	7 cm	7 cm
EQ12	12cm block	0,7 kg	15 cm	10 cm	10 cm
EQ15	15cm block	0,9 kg	15 cm	13 cm	13 cm
EQ20	20cm block	1,3 kg	15 cm	18 cm	18 cm
EQ25	25cm block	1,5 kg	15 cm	22 cm	20 cm
EQ30	30cm block	2,7 kg	25 cm	25 cm	20 cm
EQ36	36cm block	3 kg	25 cm	32 cm	20 cm

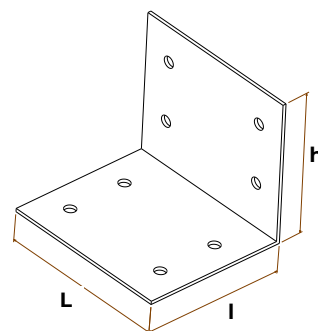

Advantages

- Flexibility on-site
- Fast implementation
- Adapts to any support
- Galvanised steel

Packaging

Sale	By part or by order
Storage	Dry



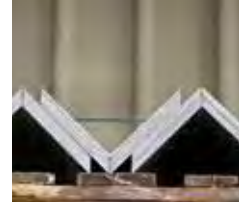

Angle bars

Technical characteristics

Masonry base

The use of angle bars is recommended when laying the first row of hemp blocks in some applications. This solution shall be preferred for exterior insulation as an alternative to a base (silica-limestone, cellular glass, etc.) when there is no adequate foundation. They can also be used in new builds to support hemp masonry blocks when the latter are suspended. In general, the angle bar can be used as a lintel in certain applications or can be used as a connection between two long very thick lintels.

Ref.	Usage	Weight approx	L	l	h
COR12	12cm block	5,7kg	120 cm	10 cm	10 cm
COR15	15cm block	7,4kg	120 cm	13 cm	13 cm
COR20	20cm block	10,2kg	120 cm	18 cm	18 cm
COR25	25cm block	11,7KG	120 cm	22 cm	20 cm
COR30	30cm block	12,7kg	120 cm	25 cm	20 cm
COR36	36cm block	14,5kg	120 cm	32 cm	20 cm

Ref.	Allowable loads at ULS	Max block height with 1 side coated	
COR12	705	7,8	
COR15	542	5,1	
COR20	391	3	
COR25	321	2	m
COR30	282	1,7	
COR36	220	1	

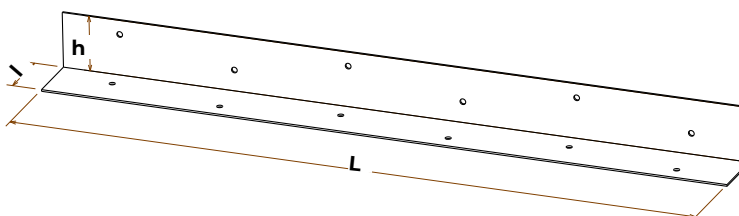

Advantages

- Adapts to any support
- Fast implementation
- Flexibility on-site
- Galvanised steel

Packaging

Sale

By part or by order

Storage

Dry



Clay base

ClayWall clay rendering is the ideal environmentally friendly solution.

It's 100% natural and has many advantages that greatly enhance the living comfort of your home. Made from raw clay and natural pigments, it's a local material of exceptional quality. It's available in many shades and gives you a durable, matte, and modern finish.

Technical characteristics

	Clay Base	Clay Finish
Apparent density	1600 kg/m ³	
Laying thickness	max 30 mm	4 - 6 mm
Consumption	16kg/m ² /cm	
Operating time	Several days of use	
Limit of use	5 to 30 degrees	

To guarantee the watertightness of a wall, a minimum thickness of 3 cm is needed.

Advantages

- Easy to implement
- Permeable to water vapour
- Acoustic comfort
- 100% natural product

Packaging

	Bags	BigBag
Dimensions of a pallet	120 x 100 x 90	80 x 120 x 95
Maximum weight of a pallet	1000kg	1200kg
Number of bags per pallet	50 bags	1 Big Bag
Bag weight	20kg	
Storage	Dry and away from moisture	
Storage life	3 months	

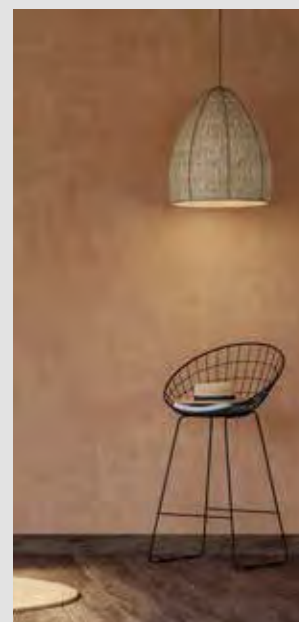

© AdobeStock

Clay finish

	A	B	C	D
1				
2				
3				
4				
5				
6				
7				
8				
9				
10				

Coatings and finishes
Clay finish

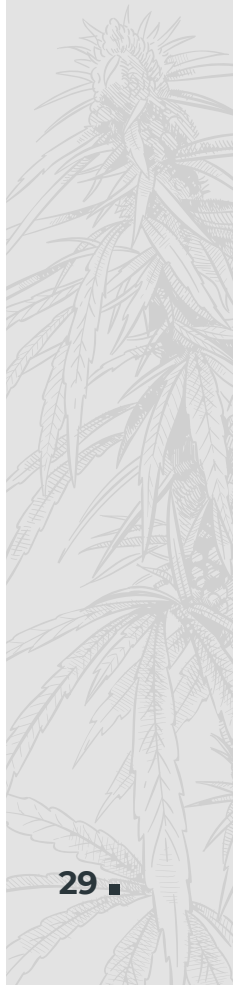



PCS

PCS interior plaster

Natural interior plaster

PCS interior plaster is an economic, sustainable, and high-quality solution. It comprises a workable mixture of gypsum, lime, and sand, ideal for plastering your walls and ceilings both for renovation and new build projects. The PCS interior plaster provides a smooth white modern finish that is ready for painting.

Technical characteristics

	Value	Unit
Bulk density	1200	kg/m ³
μ	10-12	
λ	0,73	W/mK
Layer thickness	5-25	mm
Mixing	11-12	l/bag
Consumption	12,5	kg/m ² /cm
Usage time	1,5	hours
Lifespan	5 à 30	degrees

To guarantee the watertightness of a wall, a minimum thickness of 1 cm is needed.

Advantages

- Manual or mechanical application
- Ease of use
- Open to water vapour
- A 100% natural product

Packaging

	Value	Unit
Dimensions of a pallet	120 x 100 x 90	cm
Maximum weight of a pallet	1000	kg
Number of bags per pallet	40	bags/pallet
Bag weight	25	kg
Storage	Dry and away from moisture	
Storage life	6 months from production date	

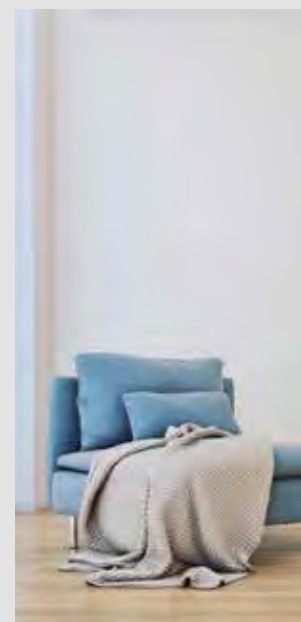

© Fotolia



isoHemp reserves the right to modify its products at any time, within legal limits and without notice. The images used are non-contractual. All texts, diagrams, photographs and illustrations are the property of IsoHemp and no reproduction is allowed without written authorization.

ENcat2022v1

We take care of your project as if it were our own. Let's discuss it!



NATURAL BUILDING STORE

Mail: sales@naturalbuildingstore.com

Tel : +44 (0)1629 34 34 20



Get a quote online at:

www.naturalbuildingstore.com

